

## GCX Mounting Assembly Installation Guide

### Philips Viridia M3 M Series Pivot Arm Wall Mount Kit



*The purpose of these instructions is to:*

- 1. Describe attachment of M Series Pivot Arm to Channel.*
- 2. Describe attachment of Quick Release Adaptor to Arm.*
- 3. Describe attachment of Viridia M3.*
- 4. Describe attachment of Down Post to Arm.*
- 5. Describe attachment of Satellite Racks.*
- 6. Describe adjustment of M Series Pivot Arm.*

### REFER TASK TO QUALIFIED PERSONNEL



#### **Before assembling the arm:**

1. Verify that the Channel has been installed and approved in accordance with the GCX Wall Channel Installation Instructions.
2. Check the weight of the device to be mounted. This arm is either rated for 30 lbs (13.6 kg) or 80 lbs (36.3 kg), depending on the front-end mounting configuration. Refer to the duty rating label located on top of the arm at the Slide pivot point. It is not recommended that you attempt to use the arm for weights outside of this range.
3. If you are unsure of your application, please contact a GCX product specialist at (707) 773-1100, (800) 228-2555 US/Canada for assistance.

#### **Installing the Arm into the Channel**

1. Install the Adjustable Stop into the top of the Channel, slide down to the bottom of the Channel and secure.
2. The Slide has (2) 1/4-20 x 3/4" SHSS set screws that, when tightened, secure the Arm at the desired location within the Channel.
3. While supporting the bottom of the Arm with one hand, guide the Slide (at the rear of the arm) into the top of the Channel.

4. Once the Arm is at the desired height, tighten both set screws using the supplied 1/8" (3 mm) hex key.

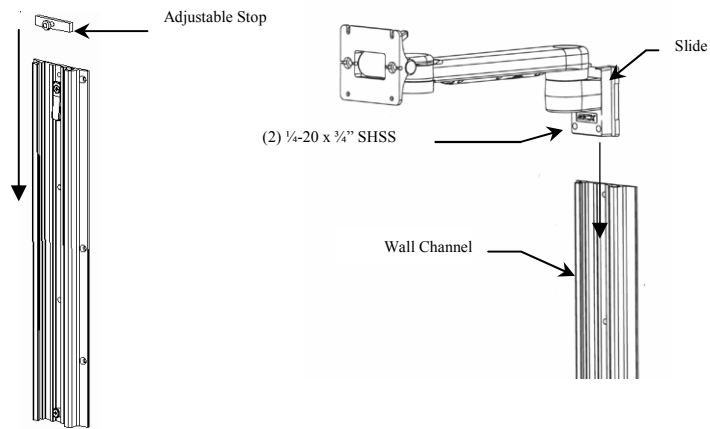

### Attaching the Quick Release Adaptor to the M Series Pivot Arm

1. Attach the Adaptor to the Philips Universal Mounting Plate by aligning the four hole pattern and secure using the supplied M4 x 12mm PHMS (4)

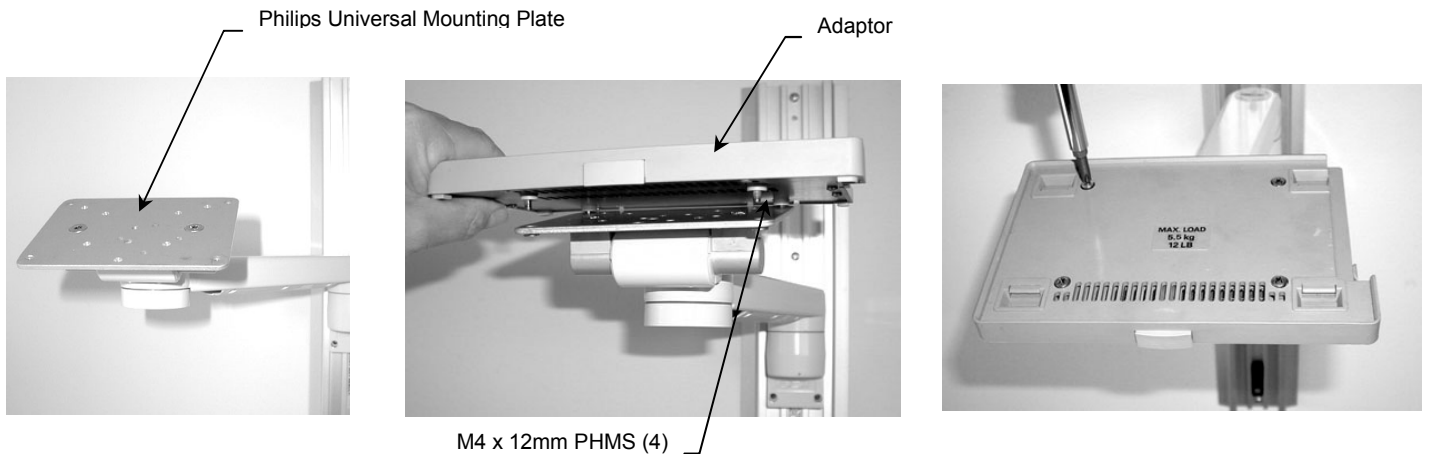

2. Mount the Viridia M3 by inserting the rear foot cleats into the rear of the Adaptor while dropping the front foot cleats in the front of the Adaptor. Both sets of cleats should snap in place, securing the monitor on the Adaptor.

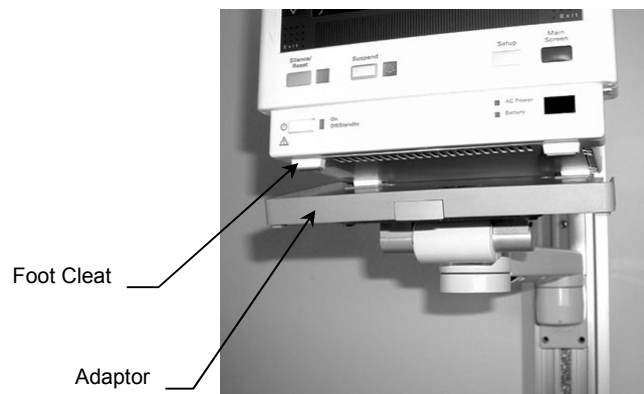

## Attaching the Down Post

1. Align the three hole pattern on the Swivel Fitting of the M Series Arm with the three hole pattern on the top of the Down Post and secure using the supplied #10-32 x 3/8" SHCS (3) and 5/32" (4mm) Hex Key.

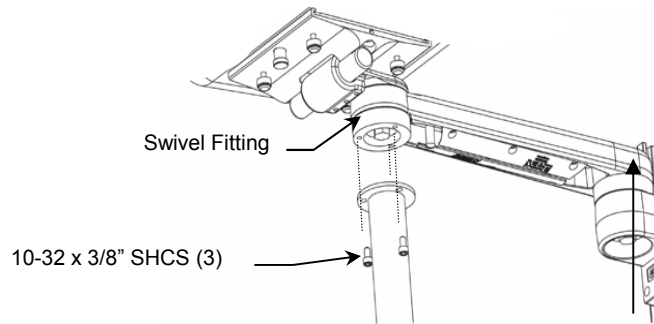

2. Attach the Satellite Racks to the Down Post by placing the Clamp around the Down Post and tightening the knob.

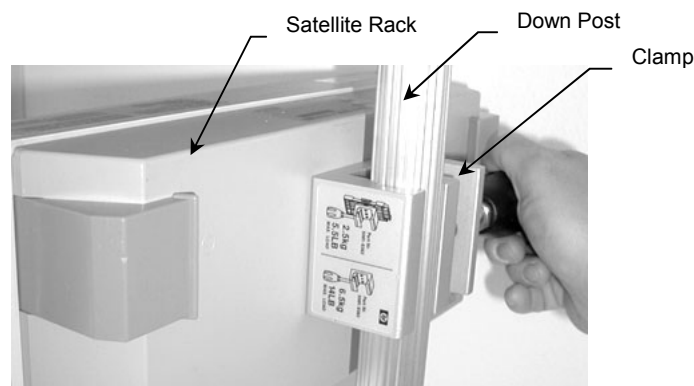

## ADJUSTMENTS

### Positioning in the Channel

**WARNING:** Never attempt to remove the mounting assembly from the Channel when loaded with a device.

1. Loosen the (2) 1/4-20 x 3/4" SHSS set screws in the Slide.
2. To raise or lower the Arm in the Channel, relieve the weight of the mounted device by lifting against the underside of the Arm, near the device. Simultaneously, push up or pull down the opposite end of the Arm just in front of the Slide.

### Pivot

1. To pivot at the Slide, simply push on the side of the Arm or mounted device.
2. To adjust the pivot tension at the Slide, use a 1/2" (or 13 mm) socket driver to tighten or loosen the Pivot Tension Bolt to obtain the desired tension.

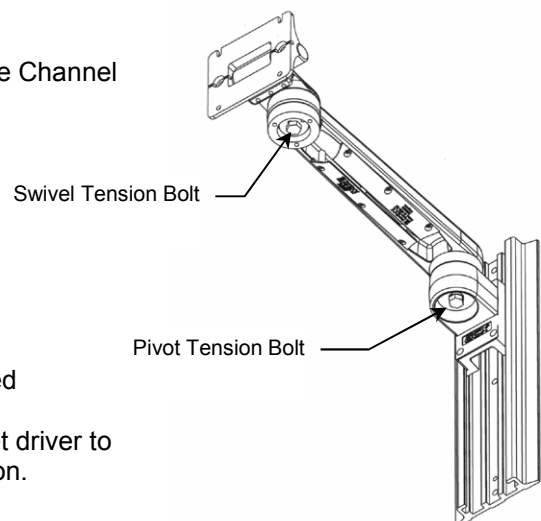

## Swivel

1. In most configurations, the mounted device will swivel at the end of the Arm. To rotate the device simply push or pull the corners of the device.
2. To adjust the swivel tension, remove cap located under the front end of the Arm and use a ½" (or 13 mm) socket driver to tighten or loosen the Swivel Tension Bolt.



Cap

## Tilt

1. In most configurations, the tilt of the mounted device can be adjusted.
2. Loosen the Adjustment Lever (if included).
3. Grasp the top and bottom of the device and tilt it to the desired angle.
4. Tighten the Adjustment Lever (if included).
5. To adjust the overall tilt tension, evenly tighten or loosen the (2) #10-32 x 5/8" SHCS Tilt Tension Adjustment Screws using the supplied 5/32 (4 mm) Hex Key.

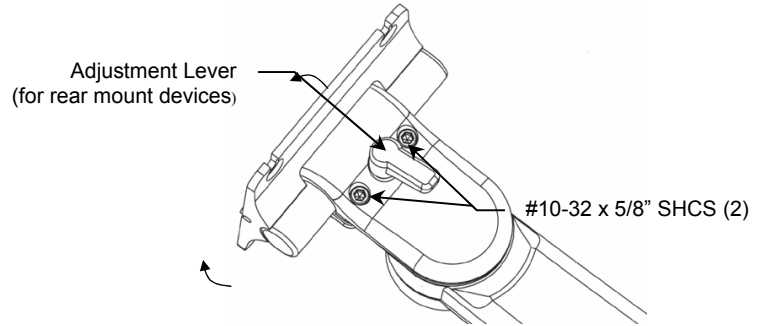

## Cable Management

Two cable management features allow convenient placement and flow cables:

1. An open cavity beneath the arm with flexible cable covers manage cables going to and from the front and rear of the arm.
2. A "pass-through" channel slide allows cables to run behind the arm within the Channel. **Note:** If cable connectors are too large to fit through the pass-through, try placing the cables in the path of the Slide before installing the arm in the Channel. Contact GCX for optional Channel Covers available to further manage the flow of cables in the Channel.

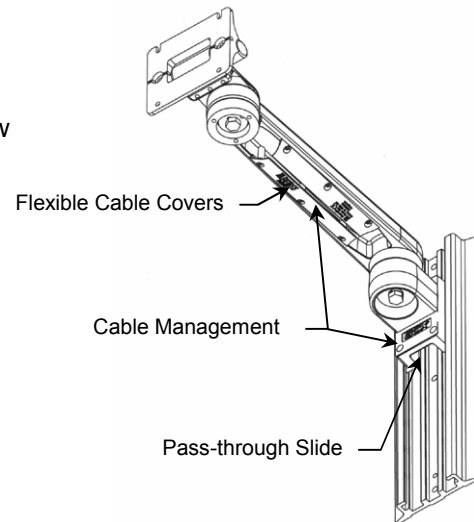

## CLEANING

1. The mounting assembly may be cleaned with most mild, non-abrasive solutions commonly used in the hospital environment (e.g. diluted bleach, ammonia, or alcohol solutions).
2. The surface finish will be permanently damaged by strong chemicals and solvents such as acetone and trichloroethylene.
3. Steel wool or other abrasive material should *never* be used.
4. Damage caused by the use of unapproved substances or processes will not be warranted. It is recommended that you test any cleaning solution on a small area of the arm that is not visible, to verify compatibility.
5. Never submerge the arm, and do not allow liquids to enter the arm. Wipe any cleaning agents off of the arm immediately, using a water-dampened cloth. Dry the arm thoroughly after cleaning.

**CAUTION:** GCX makes no claims regarding the efficacy of the listed chemicals or processes as a means for controlling infection. Consult your hospital's infection control officer or epidemiologist. To clean or sterilize mounted devices or accessory equipment, refer to the specific instructions delivered with those products.